

DATA SHEET

TDA1545A **Stereo continuous calibration DAC**

Preliminary specification
Supersedes data of March 1993
File under Integrated Circuits, IC01

1997 Sep 04

Stereo continuous calibration DAC**TDA1545A****FEATURES**

- Space saving packages
- Low power consumption
- Low total harmonic distortion
- Wide dynamic range (16-bit resolution)
- Continuous calibration concept
- Easy application: single 3 to 5.5 V rail power supply and output- and bias current are proportional to the supply voltage
- Fast settling time permits 2×, 4× and 8× oversampling (serial input) or double speed operation at 4× oversampling
- Internal bias current ensures maximum dynamic range
- Wide operating temperature range of –40 to +85 °C
- Compatible with most of the Japanese input formats: time multiplexed, two's complement and TTL
- No zero crossing distortion.

GENERAL DESCRIPTION

The TDA1545A is the first device of a new generation of the digital-to-analog converters which embodies the innovative technique of continuous calibration. The largest bit-currents are repeatedly generated by one single current reference source. This duplication is based upon an internal charge storage principle having an accuracy insensitive to ageing, temperature and process variations.

The device is fabricated in a 1.0 μm CMOS process and features an extremely low power dissipation, small package size and easy application. Furthermore, the accuracy of the high coarse current combined with the implemented symmetrical offset decoding method preclude zero-crossing distortion and ensures high quality audio reproduction. Therefore, the continuous calibration digital-to-analog converter is eminently suitable for use in (portable) digital audio equipment.

ORDERING INFORMATION

TYPE NUMBER	PACKAGE		
	NAME	DESCRIPTION	VERSION
TDA1545A	DIP8	plastic dual in-line package; 8 leads (300 mil)	SOT97-1
TDA1545AT	SO8	plastic small outline package; 8 leads; body width 3.9 mm	SOT96-1
TDA1545ATT	TSSOP14	plastic thin shrink small outline package; 14 leads; body width 4.4 mm	SOT402-1

Stereo continuous calibration DAC

TDA1545A

QUICK REFERENCE DATA

SYMBOL	PARAMETER	CONDITIONS	MIN.	TYP.	MAX.	UNIT
V_{DD}	supply voltage		3	5	5.5	V
I_{DD}	supply current	$V_{DD} = 5\text{ V}$; at code 0000H	–	3.0	4.0	mA
I_{FS}	full-scale output current	$V_{DD} = 5\text{ V}$ $V_{DD} = 3\text{ V}$	0.9 –	1.0 0.6	1.1 –	mA mA
THD	total harmonic distortion	including noise at 0 dB at 0 dB at –60 dB at –60 dB at –60 dB; A-weighting at –60 dB; A-weighting at –60 dB; A-weighting; $R3 = R4 = 11\text{ k}\Omega$; $I_{FS} = 2\text{ mA}$	– – – – – – – – –	–88 0.004 –33 2.2 –35 1.7 1.4	–78 0.01 –24 6 – – –	dB % dB % dB % %
S/N	signal-to-noise ratio at bipolar zero	A-weighting; at code 0000H $R3 = R4 = 11\text{ k}\Omega$; $I_{FS} = 2\text{ mA}$	86 –	98 101	– –	dB dB
t_{cs}	current settling time to ± 1 LSB		–	0.2	–	μs
BR	input bit rate at data input		–	–	18.4	Mbits/s
f_{BCK}	clock frequency at clock input		–	–	18.4	MHz
TC_{FS}	full-scale temperature coefficient at analog outputs (IOL; IOR)		–	± 400	–	ppm
P_{tot}	total power dissipation	at code 0000H $V_{DD} = 5\text{ V}$ $V_{DD} = 3\text{ V}$	– –	15 6	20 –	mW mW
T_{amb}	operating ambient temperature		–40	–	+85	$^{\circ}\text{C}$

Stereo continuous calibration DAC

TDA1545A

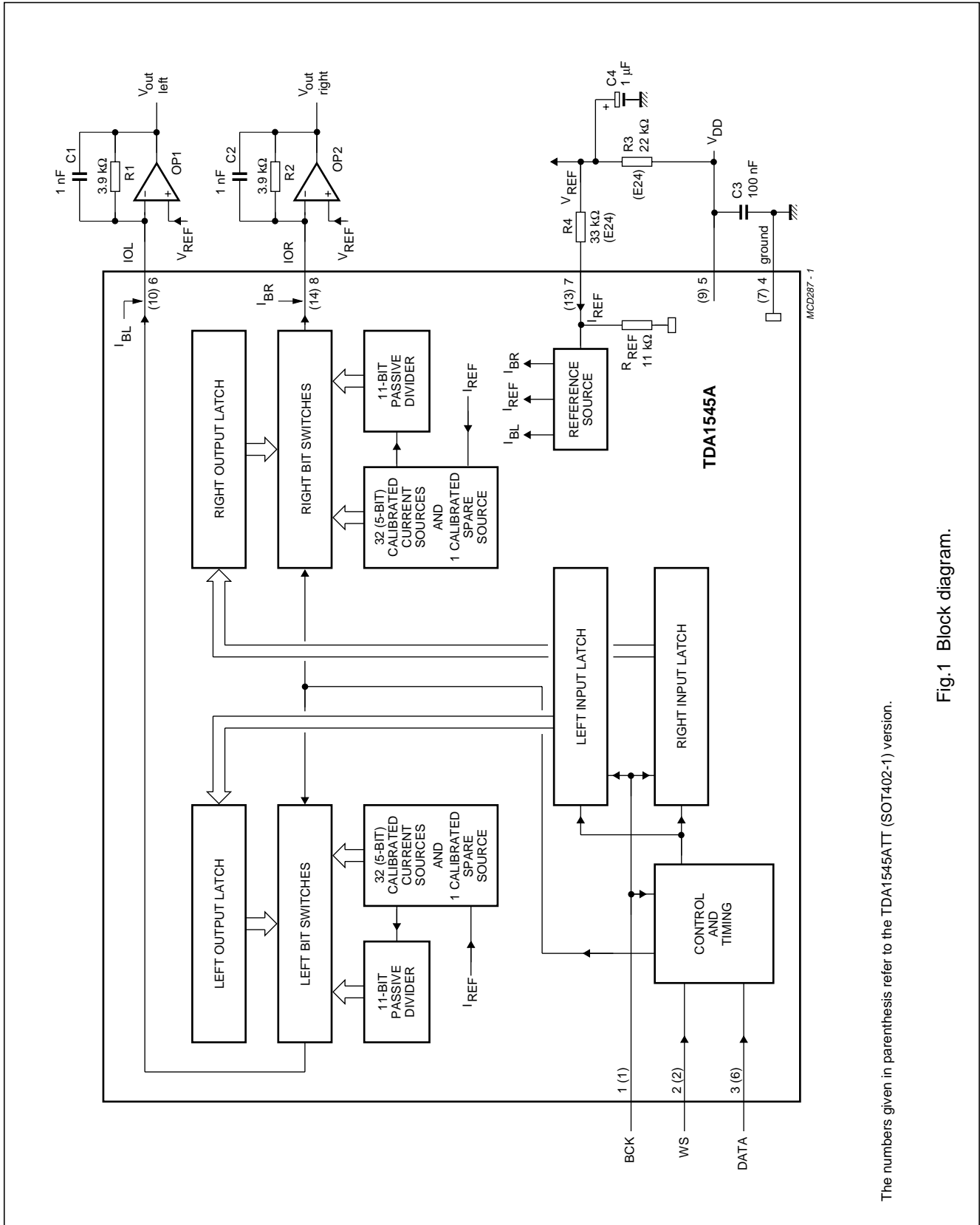

The numbers given in parenthesis refer to the TDA1545ATT (SOT402-1) version.

Fig.1 Block diagram.

Stereo continuous calibration DAC

TDA1545A

PINNING

SYMBOL	PIN		DESCRIPTION
	SOT96-1; SOT97-1	SOT402-1	
BCK	1	1	bit clock input
WS	2	2	word select input
DATA	3	6	data input
GND	4	7	ground
V _{DD}	5	9	positive supply voltage
IOL	6	10	left channel output
I _{REF}	7	13	reference current input
IOR	8	14	right channel output
n.c.	–	3, 4, 5, 8, 11, 12	not connected

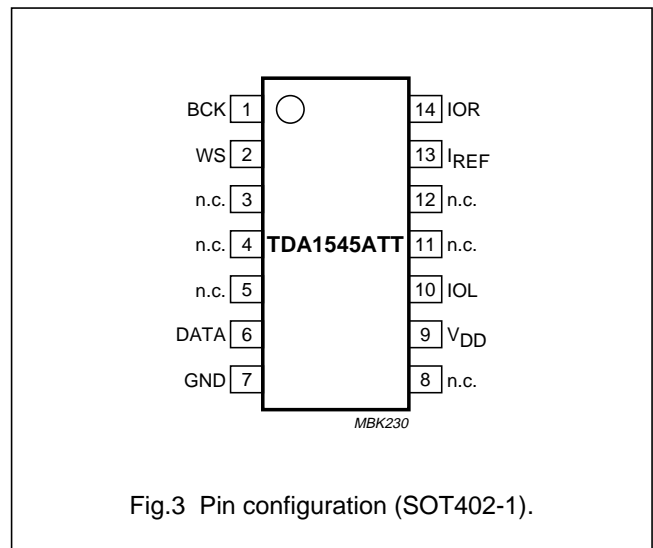
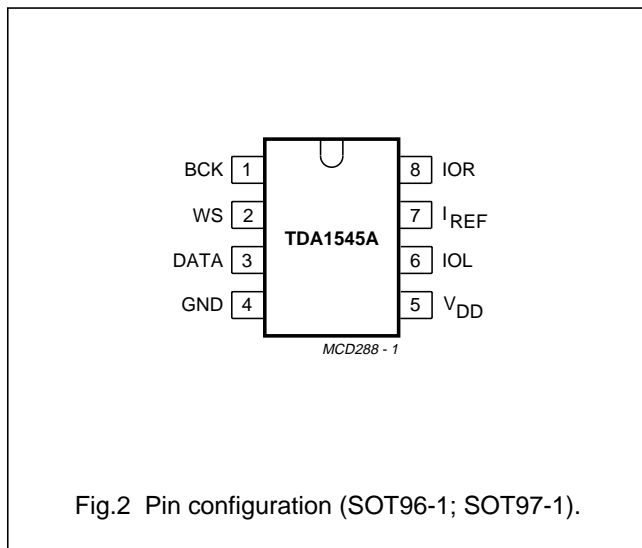

Stereo continuous calibration DAC

TDA1545A

FUNCTIONAL DESCRIPTION

The basic operation of the continuous calibration DAC is illustrated in Fig.4. The figure shows the calibration principle (Fig.4a) and operation principle (Fig.4b). During calibration of the MOS current source (Fig.4a) transistor M1 is connected as a diode by applying a reference current. The voltage V_{gs} on the intrinsic gate-source capacitance C_{gs} of M1 is then determined by the transistor characteristics. After calibration of the drain current to the reference value I_{REF} , the switch S1 is opened and S2 is switched to the other position (Fig.4b). The gate-to-source voltage V_{gs} of M1 is not changed because the charge on C_{gs} is preserved. Therefore the drain current of M1 will still be equal to I_{REF} and this exact duplicate of I_{REF} is now available at the I_{out} terminal. The 32 current sources and the spare current source of the TDA1545A are continuously calibrated (see Fig.1).

The spare current is included to allow for continuous convertor operation. The output of one calibrated source is connected to an 11-bit binary current divider consisting of 2048 transistors. A symmetrical offset decoding principle is incorporated and arranges the bit switching in such a way that the zero-crossing is performed only by the LSB currents.

Notes to the functional description

$$1. \quad I_{FS} = A_{FS} \times I_{REF} \text{ and } I_{bias} = A_{bias} \times I_{REF}$$

$$2. \quad \frac{V_{DD1}}{V_{DD2}} = \frac{I_{FS1}}{I_{FS2}} = \frac{I_{bias1}}{I_{bias2}}$$

$$3. \quad \Delta I_{REF} = I_{REF} - \frac{V_{DD}}{R3 + \Delta R3 + R4 + \Delta R4 + R_{REF} + \Delta R_{REF}}$$

The TDA1545A accepts input serial data formats of 16-bit word length. Left and right data words are time multiplexed. The most significant bit (bit 1) must always be first. The format of data input is shown in Figs 5 and 6. With a LOW level on the word select input (WS) input data is placed in the right input register and with a HIGH level on the WS input data is placed in the left input register.

The data in the input registers is simultaneously latched in the output registers which control the bit switches. An internal bias current I_{bias} (see I_{BL} and I_{BR} in Fig.1) is added to the full-scale output current I_{FS} in order to achieve the maximum dynamic range at the outputs of OP1 and OP2 (see Fig.1). The reference input current I_{REF} controls with gain A_{FS} the current I_{FS} which is a sink current and with gain A_{bias} the I_{bias} which is a source current (note 1). The current I_{REF} is proportional to V_{DD} so the I_{FS} and I_{bias} will also be proportional to V_{DD} (note 2) because A_{FS} and A_{bias} are constant.

The reference output voltage V_{REF} in Fig.1 is $\frac{2}{3}V_{DD}$. In this way the maximum dynamic range is achieved over the entire power supply range. The tolerance of the reference input current in Fig.1 depends on the tolerance of the resistors R3, R4 and R_{REF} (note 3).

Stereo continuous calibration DAC

TDA1545A

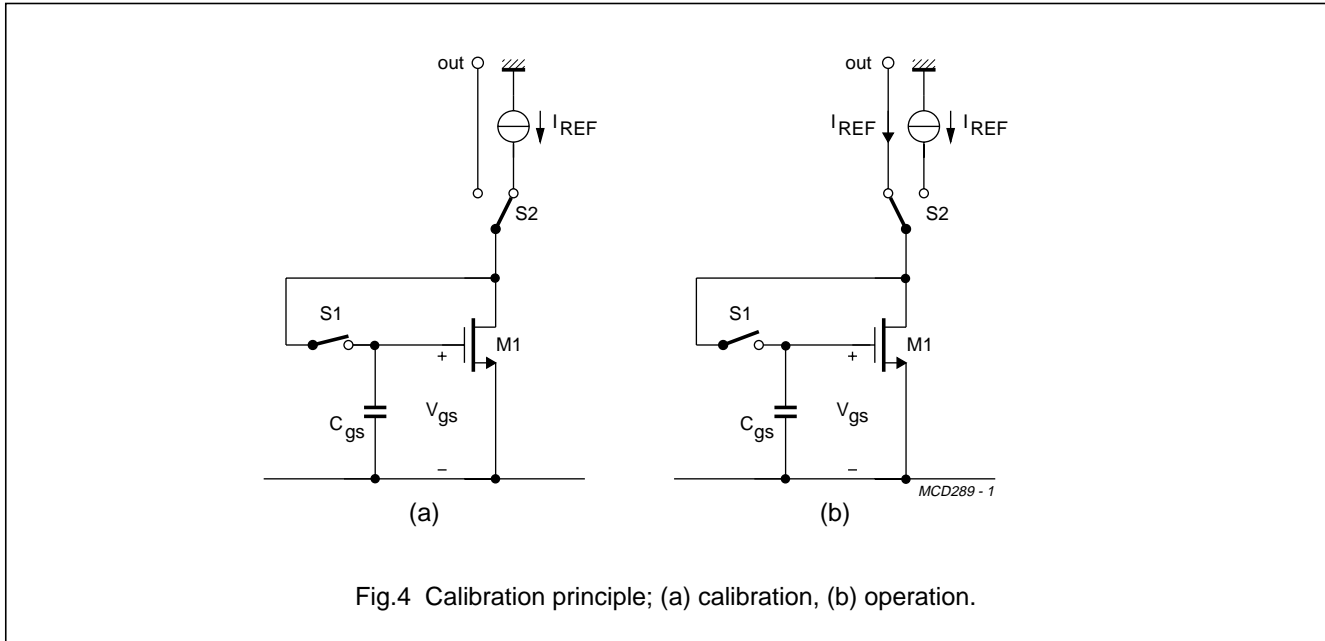

LIMITING VALUES

In accordance with the Absolute Maximum Rating System (IEC 134).

SYMBOL	PARAMETER	CONDITIONS	MIN.	MAX.	UNIT
V_P	positive supply voltage		–	6	V
$T_{xtal(max)}$	maximum crystal temperature		–	+150	°C
T_{stg}	storage temperature		–55	+150	°C
T_{amb}	operating ambient temperature		–40	+85	°C
V_{es}	electrostatic handling	note 1	–2000	+2000	V
		note 2	–200	+200	V

Notes

1. Equivalent to discharging a 100 pF capacitor via a 1.5 kΩ series resistor.
2. Machine model; C = 200 pF, L = 0.5 μH, R = 10 Ω, 3 zaps positive and negative.

THERMAL CHARACTERISTICS

SYMBOL	PARAMETER	VALUE	UNIT
$R_{th j-a}$	thermal resistance from junction to ambient in free air		
	SOT97-1	100	K/W
	SOT96-1	160	K/W
	SOT402-1	155	K/W

Stereo continuous calibration DAC

TDA1545A

CHARACTERISTICS

$V_{DD} = 5\text{ V}$; $T_{amb} = 25\text{ °C}$; measured in the circuit of Fig.1; unless otherwise specified.

SYMBOL	PARAMETER	CONDITIONS	MIN.	TYP.	MAX.	UNIT
V_{DD}	supply voltage		3.0	5.0	5.5	V
I_{DD}	supply current	note 1	–	3.0	4.0	mA
RR	ripple rejection	note 2	–	30	–	dB
Digital inputs (WS; BCK; DATA)						
$ I_{IL} $	input leakage current LOW	$V_I = 0.8\text{ V}$	–	–	10	μA
$ I_{IH} $	input leakage current HIGH	$V_I = 2.4\text{ V}$	–	–	10	μA
f_{BCK}	bit clock input frequency		–	–	18.4	MHz
BR	bit rate data input		–	–	18.4	Mbits/s
f_{WS}	word select input		–	–	384	kHz
Timing (see Fig.5)						
t_r	rise time		–	–	12	ns
t_f	fall time		–	–	12	ns
t_{CY}	bit clock cycle time		54	–	–	ns
t_{HB}	bit clock HIGH time		15	–	–	ns
t_{LB}	bit clock LOW time		15	–	–	ns
$t_{SU;DAT}$	data set-up time		12	–	–	ns
$t_{HD;DAT}$	data hold time		2	–	–	ns
$t_{HD;WS}$	word select hold time		2	–	–	ns
$t_{SU;WS}$	word select set-up time		12	–	–	ns
Analog input (I_{REF})						
R_{REF}	reference resistor	see Fig.1	7.4	11.0	14.6	$\text{k}\Omega$
Analog outputs (IOL and IOR)						
RES	resolution		–	–	16	bit
V_{DCC}	DC output voltage compliance		2.0	–	$V_{DD} - 1$	V
I_{FS}	full-scale current		0.9	1.0	1.1	mA
T_{CFS}	full-scale temperature coefficient		–	± 400	–	ppm
I_{bias}	bias current		643	714	785	μA
A_{FS}	reference input current to full-scale output current gain		–	13.2	–	
A_{bias}	reference input current to bias current gain		–	9.42	–	

Stereo continuous calibration DAC

TDA1545A

SYMBOL	PARAMETER	CONDITIONS	MIN.	TYP.	MAX.	UNIT
THD	total harmonic distortion	including noise at 0 dB; note 3; see Fig.7	–	–88 0.004	–78 0.01	dB %
		including noise at –60 dB; note 3; Fig.7	–	–33 2.2	–24 6	dB %
		including noise at –60 dB, A-weighting	–	–35 1.8	–	dB %
		R3 = R4 = 11 kΩ see Fig.1; I _{FS} = 2 mA	–	1.4	–	%
		including noise at 0 dB; note 4	–	–84 0.006	–70 0.03	dB %
t _{cs}	settling time ±1 LSB		–	0.2	–	μs
α	channel separation		86	95	–	dB
d _{IO}	unbalance between outputs	note 3	–	0.2	0.3	dB
t _d	delay time between outputs		–	±0.2	–	μs
S/N	signal-to-noise ratio (A-weighting)	at bipolar zero note 1	86	98	–	dB
		note 5	–	101	–	dB

Notes

1. At code 0000H.
2. V_{ripple} = 1% of supply voltage and f_{ripple} = 100 Hz.
3. Measured with 1 kHz sinewave generated at a sampling rate of 192 kHz.
4. Measured with 1 kHz sinewave over a 20 Hz to 20 kHz bandwidth generated at a sampling rate of 192 kHz.
5. R3 = R4 = 11 kΩ; see Fig.1; I_{FS} = 2 mA.

Stereo continuous calibration DAC

TDA1545A

TEST AND APPLICATION INFORMATION

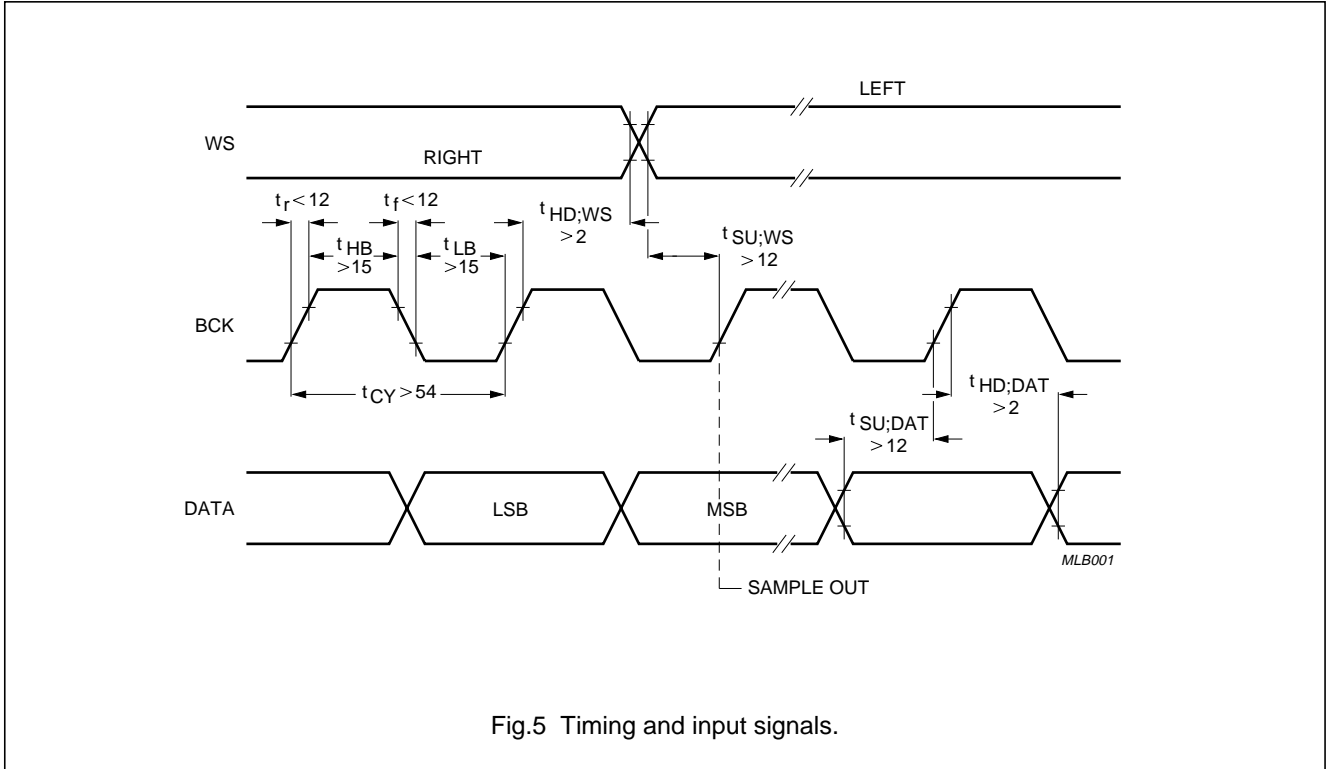

Fig.5 Timing and input signals.

Stereo continuous calibration DAC

TDA1545A

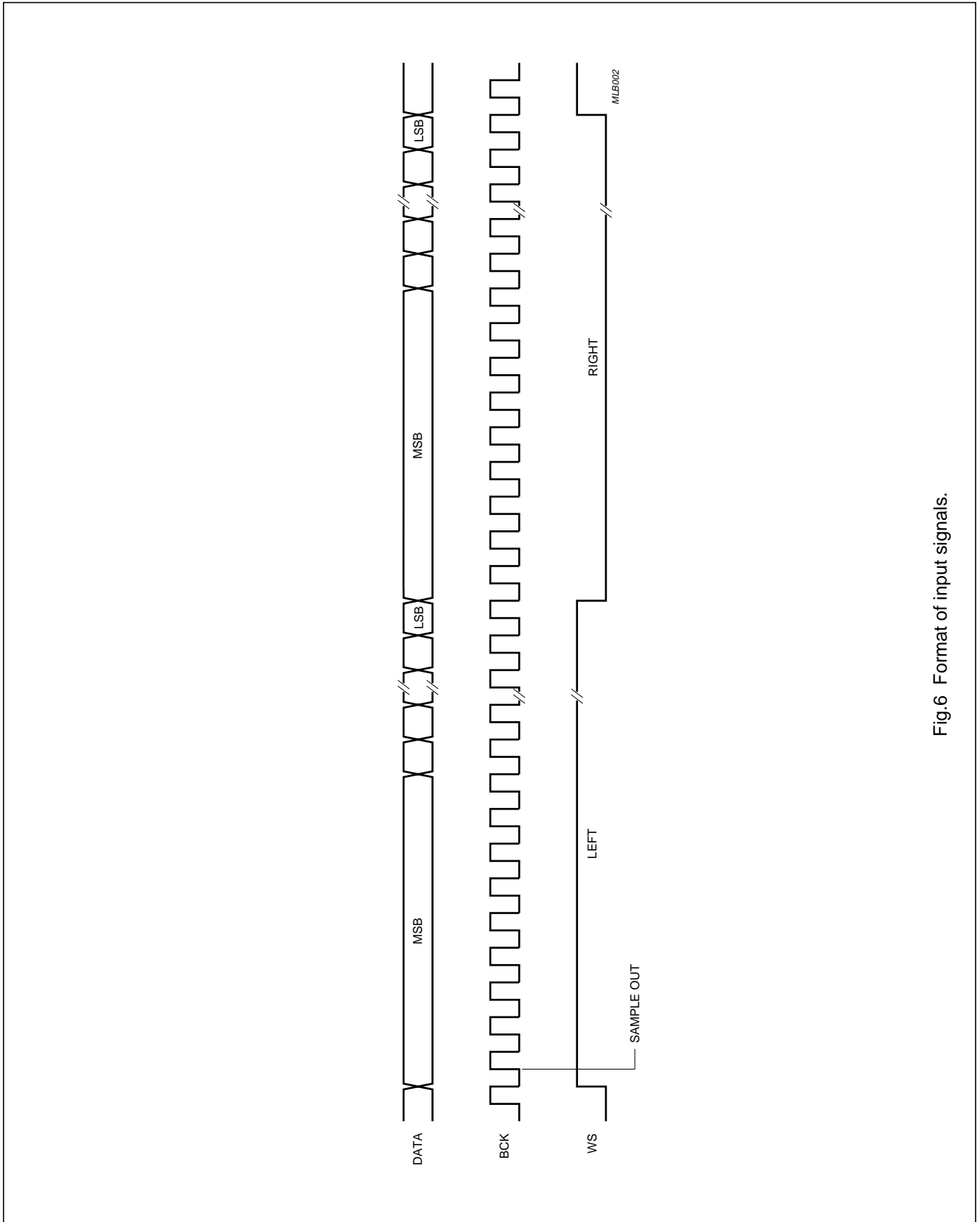

Fig.6 Format of input signals.

Stereo continuous calibration DAC

TDA1545A

APPLICATION INFORMATION

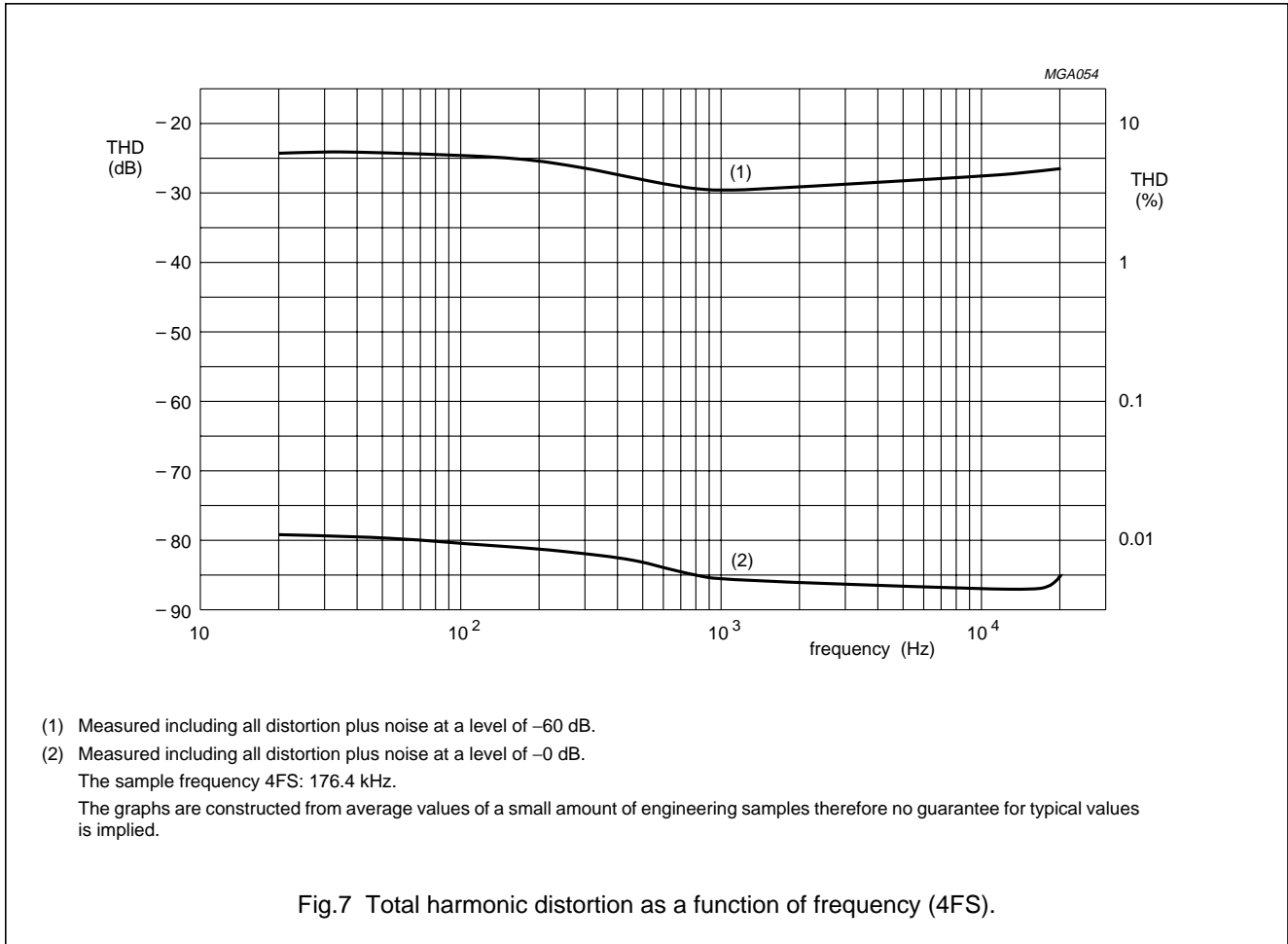
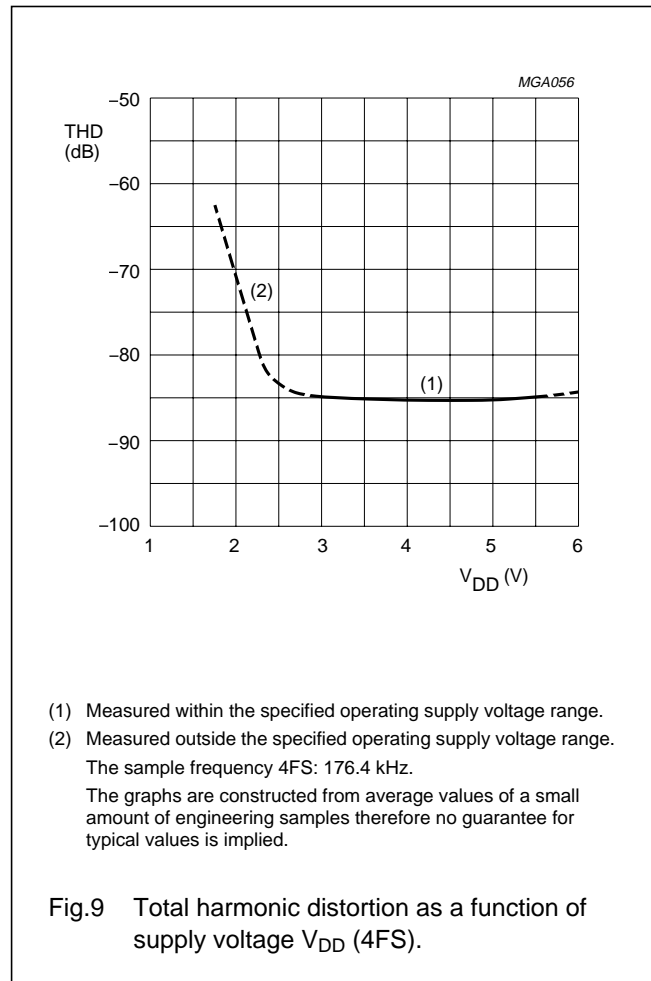
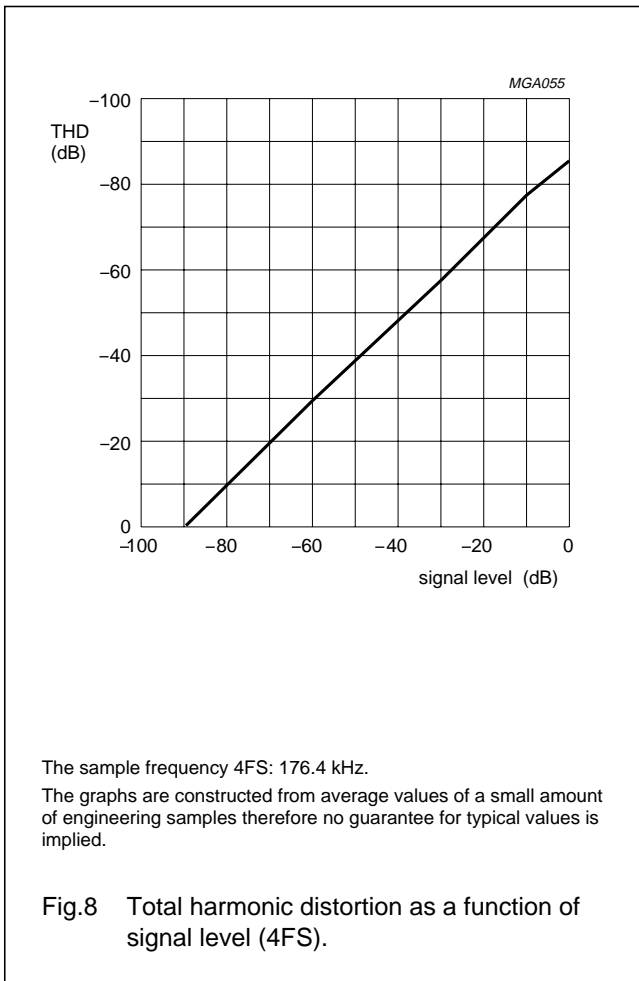

Fig.7 Total harmonic distortion as a function of frequency (4FS).

Stereo continuous calibration DAC

TDA1545A



Stereo continuous calibration DAC

TDA1545A

PACKAGE OUTLINES

DIP8: plastic dual in-line package; 8 leads (300 mil)

SOT97-1

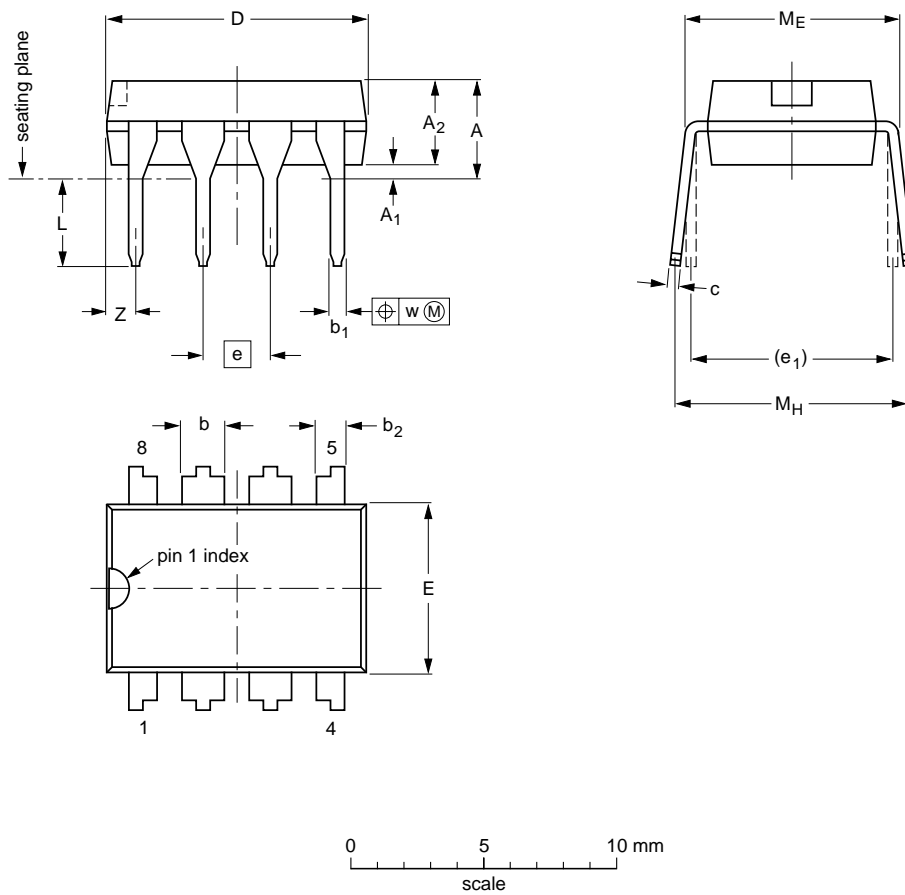

DIMENSIONS (inch dimensions are derived from the original mm dimensions)

UNIT	A max.	A ₁ min.	A ₂ max.	b	b ₁	b ₂	c	D ⁽¹⁾	E ⁽¹⁾	e	e ₁	L	M _E	M _H	w	Z ⁽¹⁾ max.
mm	4.2	0.51	3.2	1.73 1.14	0.53 0.38	1.07 0.89	0.36 0.23	9.8 9.2	6.48 6.20	2.54	7.62	3.60 3.05	8.25 7.80	10.0 8.3	0.254	1.15
inches	0.17	0.020	0.13	0.068 0.045	0.021 0.015	0.042 0.035	0.014 0.009	0.39 0.36	0.26 0.24	0.10	0.30	0.14 0.12	0.32 0.31	0.39 0.33	0.01	0.045

Note

1. Plastic or metal protrusions of 0.25 mm maximum per side are not included.

OUTLINE VERSION	REFERENCES				EUROPEAN PROJECTION	ISSUE DATE
	IEC	JEDEC	EIAJ			
SOT97-1	050G01	MO-001AN				92-11-17 95-02-04

Stereo continuous calibration DAC

TDA1545A

S08: plastic small outline package; 8 leads; body width 3.9 mm

SOT96-1

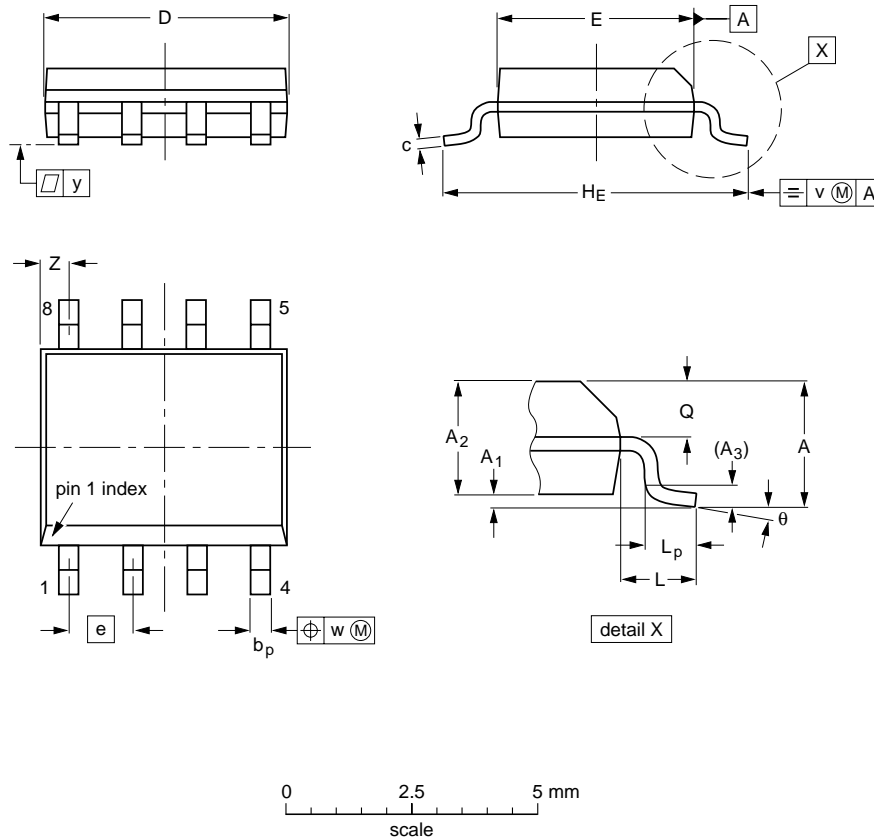

DIMENSIONS (inch dimensions are derived from the original mm dimensions)

UNIT	A max.	A ₁	A ₂	A ₃	b _p	c	D ⁽¹⁾	E ⁽²⁾	e	H _E	L	L _p	Q	v	w	y	z ⁽¹⁾	θ
mm	1.75	0.25 0.10	1.45 1.25	0.25	0.49 0.36	0.25 0.19	5.0 4.8	4.0 3.8	1.27	6.2 5.8	1.05	1.0 0.4	0.7 0.6	0.25	0.25	0.1	0.7 0.3	8° 0°
inches	0.069	0.010 0.004	0.057 0.049	0.01	0.019 0.014	0.0100 0.0075	0.20 0.19	0.16 0.15	0.050	0.244 0.228	0.041	0.039 0.016	0.028 0.024	0.01	0.01	0.004	0.028 0.012	

Notes

1. Plastic or metal protrusions of 0.15 mm maximum per side are not included.
2. Plastic or metal protrusions of 0.25 mm maximum per side are not included.

OUTLINE VERSION	REFERENCES			EUROPEAN PROJECTION	ISSUE DATE
	IEC	JEDEC	EIAJ		
SOT96-1	076E03S	MS-012AA			95-02-04 97-05-22

Stereo continuous calibration DAC

TDA1545A

TSSOP14: plastic thin shrink small outline package; 14 leads; body width 4.4 mm

SOT402-1

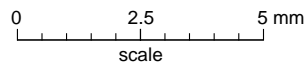
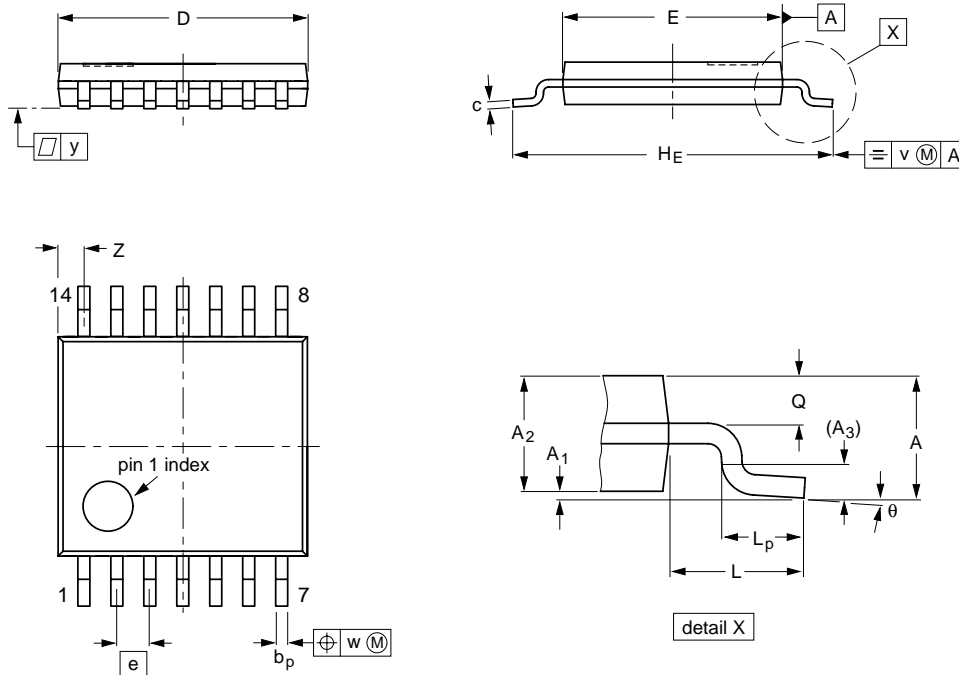

DIMENSIONS (mm are the original dimensions)

UNIT	A max.	A ₁	A ₂	A ₃	b _p	c	D ⁽¹⁾	E ⁽²⁾	e	H _E	L	L _p	Q	v	w	y	Z ⁽¹⁾	θ
mm	1.10	0.15 0.05	0.95 0.80	0.25	0.30 0.19	0.2 0.1	5.1 4.9	4.5 4.3	0.65	6.6 6.2	1.0	0.75 0.50	0.4 0.3	0.2	0.13	0.1	0.72 0.38	8° 0°

Notes

1. Plastic or metal protrusions of 0.15 mm maximum per side are not included.
2. Plastic interlead protrusions of 0.25 mm maximum per side are not included.

OUTLINE VERSION	REFERENCES				EUROPEAN PROJECTION	ISSUE DATE
	IEC	JEDEC	EIAJ			
SOT402-1		MO-153				94-07-12 95-04-04

Stereo continuous calibration DAC

TDA1545A

SOLDERING**Introduction**

There is no soldering method that is ideal for all IC packages. Wave soldering is often preferred when through-hole and surface mounted components are mixed on one printed-circuit board. However, wave soldering is not always suitable for surface mounted ICs, or for printed-circuits with high population densities. In these situations reflow soldering is often used.

This text gives a very brief insight to a complex technology. A more in-depth account of soldering ICs can be found in our "IC Package Databook" (order code 9398 652 90011).

DIP**SOLDERING BY DIPPING OR BY WAVE**

The maximum permissible temperature of the solder is 260 °C; solder at this temperature must not be in contact with the joint for more than 5 seconds. The total contact time of successive solder waves must not exceed 5 seconds.

The device may be mounted up to the seating plane, but the temperature of the plastic body must not exceed the specified maximum storage temperature ($T_{stg\ max}$). If the printed-circuit board has been pre-heated, forced cooling may be necessary immediately after soldering to keep the temperature within the permissible limit.

REPAIRING SOLDERED JOINTS

Apply a low voltage soldering iron (less than 24 V) to the lead(s) of the package, below the seating plane or not more than 2 mm above it. If the temperature of the soldering iron bit is less than 300 °C it may remain in contact for up to 10 seconds. If the bit temperature is between 300 and 400 °C, contact may be up to 5 seconds.

SO and TSSOP**REFLOW SOLDERING**

Reflow soldering techniques are suitable for all SO and TSSOP packages.

Reflow soldering requires solder paste (a suspension of fine solder particles, flux and binding agent) to be applied to the printed-circuit board by screen printing, stencilling or pressure-syringe dispensing before package placement.

Several techniques exist for reflowing; for example, thermal conduction by heated belt. Dwell times vary between 50 and 300 seconds depending on heating method.

Typical reflow temperatures range from 215 to 250 °C. Preheating is necessary to dry the paste and evaporate the binding agent. Preheating duration: 45 minutes at 45 °C.

WAVE SOLDERING

Wave soldering can be used for all SO packages. Wave soldering is **not** recommended for TSSOP packages, because of the likelihood of solder bridging due to closely-spaced leads and the possibility of incomplete solder penetration in multi-lead devices.

If wave soldering is used - **and cannot be avoided for TSSOP packages** - the following conditions must be observed:

- A double-wave (a turbulent wave with high upward pressure followed by a smooth laminar wave) soldering technique should be used.
- The longitudinal axis of the package footprint must be parallel to the solder flow and must incorporate solder thieves at the downstream end.

Even with these conditions, do not consider wave soldering TSSOP packages with 48 leads or more, that is TSSOP48 (SOT362-1) and TSSOP56 (SOT364-1).

During placement and before soldering, the package must be fixed with a droplet of adhesive. The adhesive can be applied by screen printing, pin transfer or syringe dispensing. The package can be soldered after the adhesive is cured.

Maximum permissible solder temperature is 260 °C, and maximum duration of package immersion in solder is 10 seconds, if cooled to less than 150 °C within 6 seconds. Typical dwell time is 4 seconds at 250 °C.

A mildly-activated flux will eliminate the need for removal of corrosive residues in most applications.

REPAIRING SOLDERED JOINTS

Fix the component by first soldering two diagonally-opposite end leads. Use only a low voltage soldering iron (less than 24 V) applied to the flat part of the lead. Contact time must be limited to 10 seconds at up to 300 °C. When using a dedicated tool, all other leads can be soldered in one operation within 2 to 5 seconds between 270 and 320 °C.

Stereo continuous calibration DAC

TDA1545A

DEFINITIONS

Data sheet status	
Objective specification	This data sheet contains target or goal specifications for product development.
Preliminary specification	This data sheet contains preliminary data; supplementary data may be published later.
Product specification	This data sheet contains final product specifications.
Limiting values	
Limiting values given are in accordance with the Absolute Maximum Rating System (IEC 134). Stress above one or more of the limiting values may cause permanent damage to the device. These are stress ratings only and operation of the device at these or at any other conditions above those given in the Characteristics sections of the specification is not implied. Exposure to limiting values for extended periods may affect device reliability.	
Application information	
Where application information is given, it is advisory and does not form part of the specification.	

LIFE SUPPORT APPLICATIONS

These products are not designed for use in life support appliances, devices, or systems where malfunction of these products can reasonably be expected to result in personal injury. Philips customers using or selling these products for use in such applications do so at their own risk and agree to fully indemnify Philips for any damages resulting from such improper use or sale.

Stereo continuous calibration DAC

TDA1545A

NOTES

Philips Semiconductors – a worldwide company

Argentina: see South America

Australia: 34 Waterloo Road, NORTH RYDE, NSW 2113,
Tel. +61 2 9805 4455, Fax. +61 2 9805 4466

Austria: Computerstr. 6, A-1101 WIEN, P.O. Box 213, Tel. +43 160 1010,
Fax. +43 160 101 1210

Belarus: Hotel Minsk Business Center, Bld. 3, r. 1211, Volodarski Str. 6,
220050 MINSK, Tel. +375 172 200 733, Fax. +375 172 200 773

Belgium: see The Netherlands

Brazil: see South America

Bulgaria: Philips Bulgaria Ltd., Energoproject, 15th floor,
51 James Bourchier Blvd., 1407 SOFIA,
Tel. +359 2 689 211, Fax. +359 2 689 102

Canada: PHILIPS SEMICONDUCTORS/COMPONENTS,
Tel. +1 800 234 7381

China/Hong Kong: 501 Hong Kong Industrial Technology Centre,
72 Tat Chee Avenue, Kowloon Tong, HONG KONG,
Tel. +852 2319 7888, Fax. +852 2319 7700

Colombia: see South America

Czech Republic: see Austria

Denmark: Prags Boulevard 80, PB 1919, DK-2300 COPENHAGEN S,
Tel. +45 32 88 2636, Fax. +45 31 57 0044

Finland: Sinikalliontie 3, FIN-02630 ESPOO,
Tel. +358 9 615800, Fax. +358 9 61580920

France: 4 Rue du Port-aux-Vins, BP317, 92156 SURESNES Cedex,
Tel. +33 1 40 99 6161, Fax. +33 1 40 99 6427

Germany: Hammerbrookstraße 69, D-20097 HAMBURG,
Tel. +49 40 23 53 60, Fax. +49 40 23 536 300

Greece: No. 15, 25th March Street, GR 17778 TAVROS/ATHENS,
Tel. +30 1 4894 339/239, Fax. +30 1 4814 240

Hungary: see Austria

India: Philips INDIA Ltd, Band Box Building, 2nd floor,
254-D, Dr. Annie Besant Road, Worli, MUMBAI 400 025,
Tel. +91 22 493 8541, Fax. +91 22 493 0966

Indonesia: see Singapore

Ireland: Newstead, Clonskeagh, DUBLIN 14,
Tel. +353 1 7640 000, Fax. +353 1 7640 200

Israel: RAPAC Electronics, 7 Kehilat Saloniki St, PO Box 18053,
TEL AVIV 61180, Tel. +972 3 645 0444, Fax. +972 3 649 1007

Italy: PHILIPS SEMICONDUCTORS, Piazza IV Novembre 3,
20124 MILANO, Tel. +39 2 6752 2531, Fax. +39 2 6752 2557

Japan: Philips Bldg 13-37, Kohnan 2-chome, Minato-ku, TOKYO 108,
Tel. +81 3 3740 5130, Fax. +81 3 3740 5077

Korea: Philips House, 260-199 Itaewon-dong, Yongsan-ku, SEOUL,
Tel. +82 2 709 1412, Fax. +82 2 709 1415

Malaysia: No. 76 Jalan Universiti, 46200 PETALING JAYA, SELANGOR,
Tel. +60 3 750 5214, Fax. +60 3 757 4880

Mexico: 5900 Gateway East, Suite 200, EL PASO, TEXAS 79905,
Tel. +9-5 800 234 7381

Middle East: see Italy

Netherlands: Postbus 90050, 5600 PB EINDHOVEN, Bldg. VB,
Tel. +31 40 27 82785, Fax. +31 40 27 88399

New Zealand: 2 Wagener Place, C.P.O. Box 1041, AUCKLAND,
Tel. +64 9 849 4160, Fax. +64 9 849 7811

Norway: Box 1, Manglerud 0612, OSLO,
Tel. +47 22 74 8000, Fax. +47 22 74 8341

Philippines: Philips Semiconductors Philippines Inc.,
106 Valero St. Salcedo Village, P.O. Box 2108 MCC, MAKATI,
Metro MANILA, Tel. +63 2 816 6380, Fax. +63 2 817 3474

Poland: Ul. Lukiska 10, PL 04-123 WARSZAWA,
Tel. +48 22 612 2831, Fax. +48 22 612 2327

Portugal: see Spain

Romania: see Italy

Russia: Philips Russia, Ul. Usatcheva 35A, 119048 MOSCOW,
Tel. +7 095 755 6918, Fax. +7 095 755 6919

Singapore: Lorong 1, Toa Payoh, SINGAPORE 1231,
Tel. +65 350 2538, Fax. +65 251 6500

Slovakia: see Austria

Slovenia: see Italy

South Africa: S.A. PHILIPS Pty Ltd., 195-215 Main Road Martindale,
2092 JOHANNESBURG, P.O. Box 7430 Johannesburg 2000,
Tel. +27 11 470 5911, Fax. +27 11 470 5494

South America: Rua do Rocio 220, 5th floor, Suite 51,
04552-903 São Paulo, SÃO PAULO - SP, Brazil,
Tel. +55 11 821 2333, Fax. +55 11 829 1849

Spain: Balmes 22, 08007 BARCELONA,
Tel. +34 3 301 6312, Fax. +34 3 301 4107

Sweden: Kottbygatan 7, Akalla, S-16485 STOCKHOLM,
Tel. +46 8 632 2000, Fax. +46 8 632 2745

Switzerland: Allmendstrasse 140, CH-8027 ZÜRICH,
Tel. +41 1 488 2686, Fax. +41 1 481 7730

Taiwan: Philips Semiconductors, 6F, No. 96, Chien Kuo N. Rd., Sec. 1,
TAIPEI, Taiwan Tel. +886 2 2134 2865, Fax. +886 2 2134 2874

Thailand: PHILIPS ELECTRONICS (THAILAND) Ltd.,
209/2 Sanpavuth-Bangna Road Prakanong, BANGKOK 10260,
Tel. +66 2 745 4090, Fax. +66 2 398 0793

Turkey: Talatpasa Cad. No. 5, 80640 GÜLTEPE/ISTANBUL,
Tel. +90 212 279 2770, Fax. +90 212 282 6707

Ukraine: PHILIPS UKRAINE, 4 Patrice Lumumba str., Building B, Floor 7,
252042 KIEV, Tel. +380 44 264 2776, Fax. +380 44 268 0461

United Kingdom: Philips Semiconductors Ltd., 276 Bath Road, Hayes,
MIDDLESEX UB3 5BX, Tel. +44 181 730 5000, Fax. +44 181 754 8421

United States: 811 East Arques Avenue, SUNNYVALE, CA 94088-3409,
Tel. +1 800 234 7381

Uruguay: see South America

Vietnam: see Singapore

Yugoslavia: PHILIPS, Trg N. Pasica 5/v, 11000 BEOGRAD,
Tel. +381 11 625 344, Fax. +381 11 635 777

For all other countries apply to: Philips Semiconductors, Marketing & Sales Communications,
Building BE-p, P.O. Box 218, 5600 MD EINDHOVEN, The Netherlands, Fax. +31 40 27 24825

Internet: <http://www.semiconductors.philips.com>

© Philips Electronics N.V. 1997

SCA55

All rights are reserved. Reproduction in whole or in part is prohibited without the prior written consent of the copyright owner.

The information presented in this document does not form part of any quotation or contract, is believed to be accurate and reliable and may be changed without notice. No liability will be accepted by the publisher for any consequence of its use. Publication thereof does not convey nor imply any license under patent- or other industrial or intellectual property rights.

Printed in The Netherlands

547027/1200/03/pp20

Date of release: 1997 Sep 04

Document order number: 9397 750 02703

Let's make things better.

**Philips
Semiconductors**



PHILIPS

Copyright © Each Manufacturing Company.

All Datasheets cannot be modified without permission.

This datasheet has been download from :

www.AllDataSheet.com

100% Free DataSheet Search Site.

Free Download.

No Register.

Fast Search System.

www.AllDataSheet.com